

## Testing Receiver Sensitivity for a WiFi Device

**Goal:** Setup and run a Receiver Sensitivity test for an AP using the LANforge CT523c or similar system in order to test how well the AP can receive packets with different MCS at different RF Signal levels.

In this test scenario, the LANforge CT523c is used to generate packets at specific MCS and spatial streams at a range of attenuation. This example assumes you are familiar with Chamber View, and that you have a LANforge system with a wave-2 WiFi Card, a programmable attenuator like the CT704b and two isolation chambers like the CT820a. The AP should be in one chamber, the LANforge system is in the other chamber, and the Attenuator is cabled between them. This feature is in LANforge version 5.3.9 and higher.

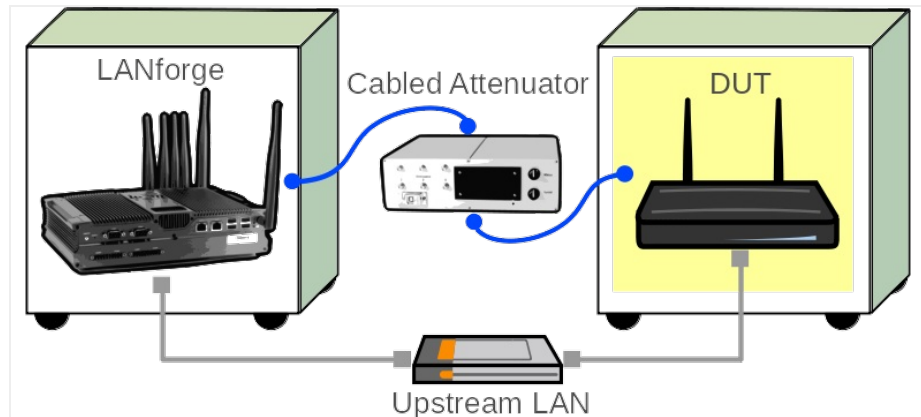

1. Configure Chamber View for Dataplane and Similar Tests.

- A. Open Chamber View by clicking on the 'Chamber View' button in the LANforge-GUI. If you have an appropriate scenario already created, then skip to the next section, otherwise you will need to build a scenario that matches your system. You can right-click in Chamber-View to create various objects.

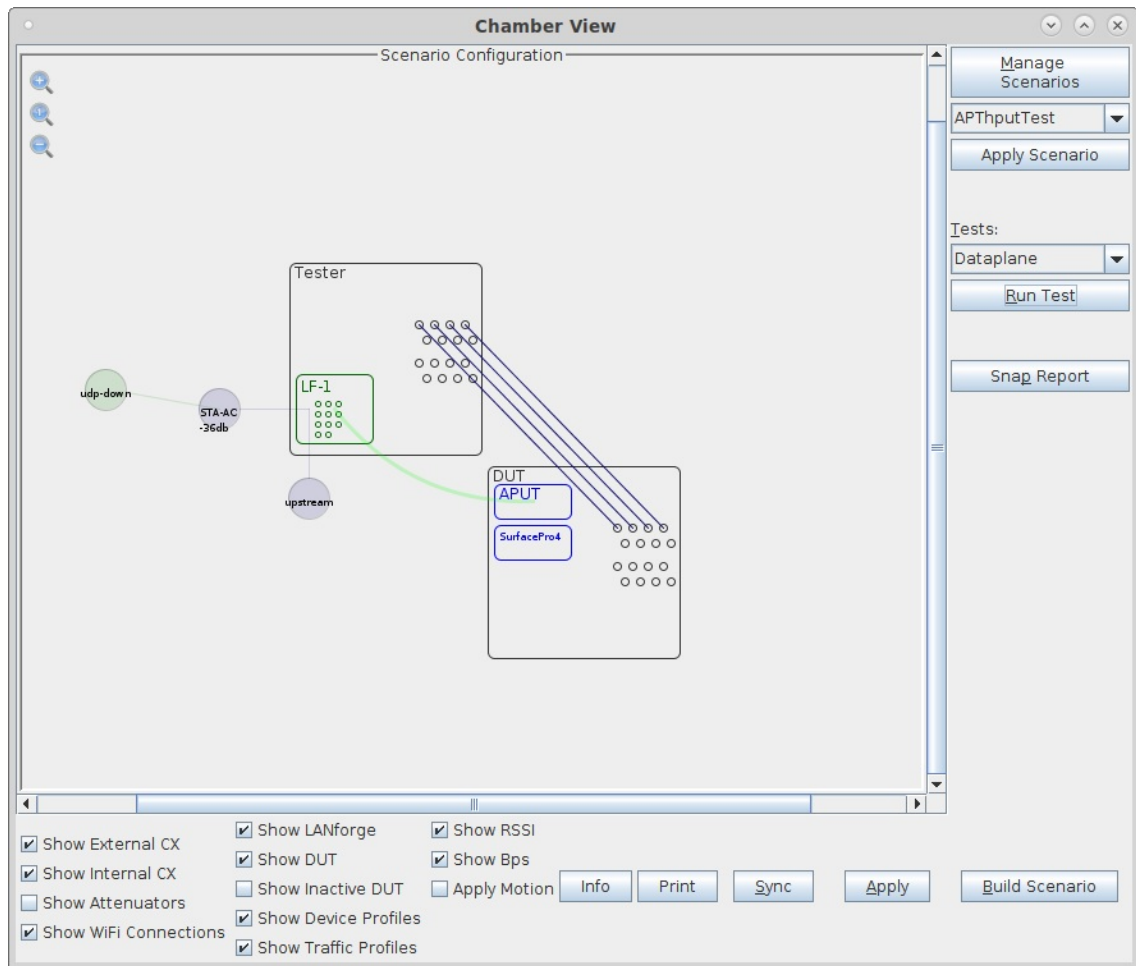

- B. Create a Device Under Test (DUT) Profile that matches your AP. The BSSID is important to be configured so that LANforge knows when it is connected to the correct AP.

The 'Create/Modify DUT' dialog box contains the following fields and options:

Name	APUT	Image file	
SW Info	v5.62.1	HW Info	
Model Number	AP640	Serial Number	234-23-sd-35
Serial port		WAN	
LAN		API version	0
SSID-1	labap	Password-1	Lanforge12345!
SSID-2		Password-2	
SSID-3		Password-3	
Mgt IP	0.0.0.0	Ant-1	0
Ant-2	0	Ant-3	0
BSSID-1	78:d2:94:bf:16:43	BSSID-2	00:00:00:00:00:00
BSSID-3	00:00:00:00:00:00	<input checked="" type="checkbox"/> Active	<input checked="" type="checkbox"/> AP DUT
<input type="checkbox"/> STA DUT	<input type="checkbox"/> WEP	<input type="checkbox"/> WPA	<input checked="" type="checkbox"/> WPA2
<input type="checkbox"/> WPA3	<input checked="" type="checkbox"/> Provides DHCP on LAN	<input type="checkbox"/> Provides DHCP on WAN	

Notes: [Empty text area]

Buttons: Apply, OK, Cancel



E. Configure an Upstream profile using eth1 on the LANforge system.

**Create/Modify Profile**

Name:  Type:

Mode:  Antennas:

Instances:  Frequency:

SSID:

Pattern:   DHCP Server  WEP

WPA  WPA2  WPA3  802.11r

802.1x EAP-TTLS  Restart DHCP on Connect

Notes:

F. Configure an STA profile on the LANforge system.

**Create/Modify Profile**

Name:  Type:

Mode:  Antennas:

Instances:  Frequency:

SSID:

Pattern:   DHCP Server  WEP

WPA  WPA2  WPA3  802.11r

802.1x EAP-TTLS  Restart DHCP on Connect

Notes:

G. Configure a Chamber View Scenario and add the STA profile (mapped to desired wiphyX radio and DUT). Add an upstream profile mapped to DUT LAN side (or possibly WAN side if that is more appropriate for your DUT).

**Create/Modify Scenario**

Scenario Name:

Del	Resource Profile	Mod Amount	Uses-1	Uses-2	Frequency	Maps To	Traffic-1	Traffic-2	Traffic-3
<input checked="" type="checkbox"/>	1.1 STA: STA-AC	<input type="text" value="1 (1)"/>	wiphy0	AUTO	157 (5785 Mhz)	DUT: APUT Radio-1	udp-down	udp-up	NA
<input checked="" type="checkbox"/>	1.1 Upstream: upstream	<input type="text" value="1 (1)"/>	eth1	AUTO	AUTO (-1 Mhz)	DUT: APUT LAN	NA	NA	NA

2. Use Chamber View to run a Receiver Sensitivity test.

- A. Open Chamber View by clicking on the 'Chamber View' button in the LANforge-GUI. Load appropriate scenario or create a new scenario as needed. Apply the Scenario, then Build the scenario.

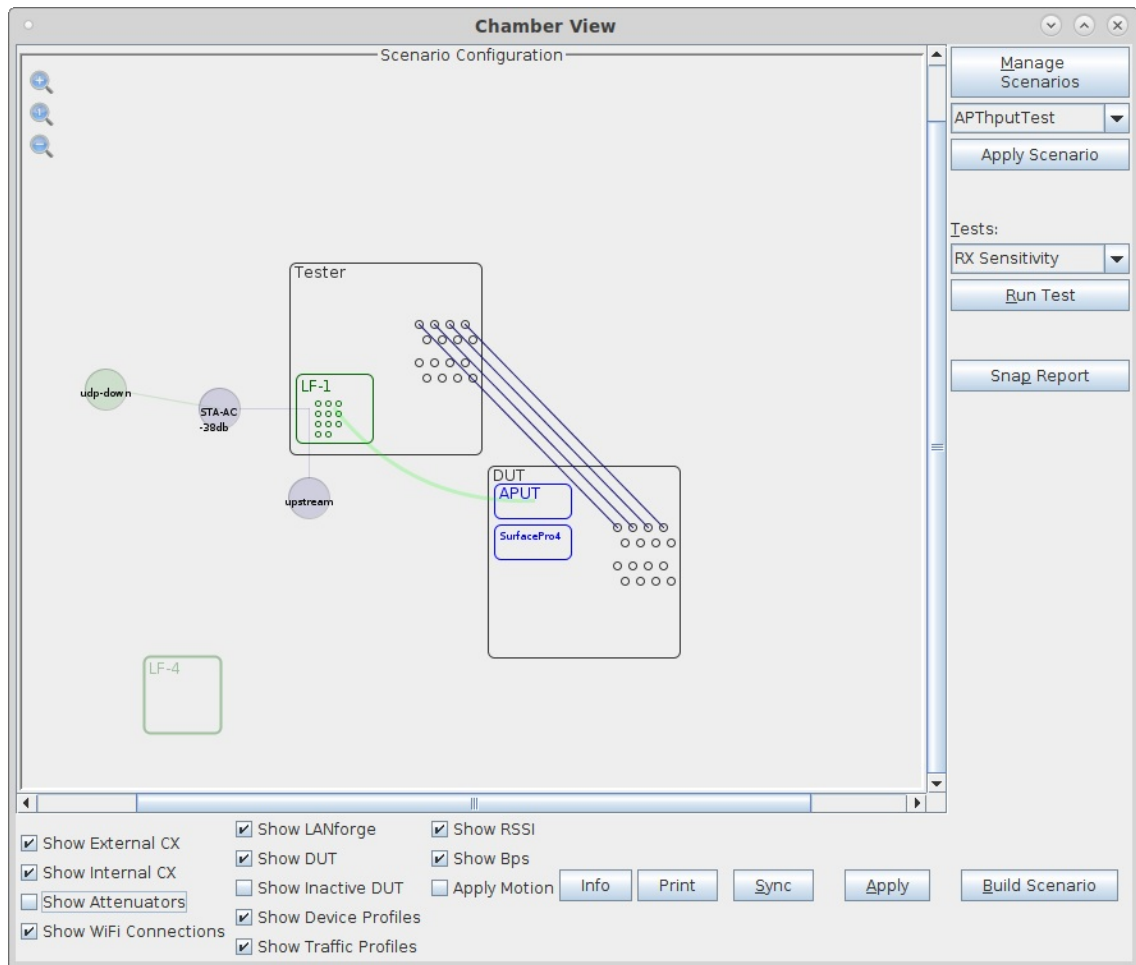

- B. Select the **RX Sensitivity** test and click **Run Test**. You should see the RX Sensitivity Test configuration window pop up. It will remember the last configuration for most fields. Select the DUT and WiFi station device, and select the combinations of traffic types you wish to send.:

**RX Sensitivity Test**

Settings | Report Configuration

Selected DUT: APUT | Duration: 5 sec (5 s)

Selected WiFi Port: 1.1.7 sta0000 | Upstream Port: 1.1.1 eth1

Path Loss: 23 | Rate: 75%

Channels	Preamble:	MCS
AUTO	CCK	0 CCK, OFDM, HT, VHT
No-Change	OFDM	1 CCK, OFDM, HT, VHT
1	HT	2 CCK, OFDM, HT, VHT
2	VHT	3 CCK, OFDM, HT, VHT
3		4 OFDM, HT, VHT
4		5 OFDM, HT, VHT

Spatial Streams	Bandwidth	Short Guard Interval:
1	20	OFF
2	40	ON
3	80	
4	160	

Retries:	Tx-Power:	Attenuator:
No Retry, No-Ack	17	1.1.71
No Retry	16	0..+30..700
2	15	
5	14	
10	13	
	12	
	11	
	10	
	9	
	8	

Start |  Another Iteration |  Pause | Close

- C. When the configuration is complete, click the **Start** button (which will change to 'Stop' once start is clicked) to start the test. An interactive report window will be created and will be updated as the test runs.

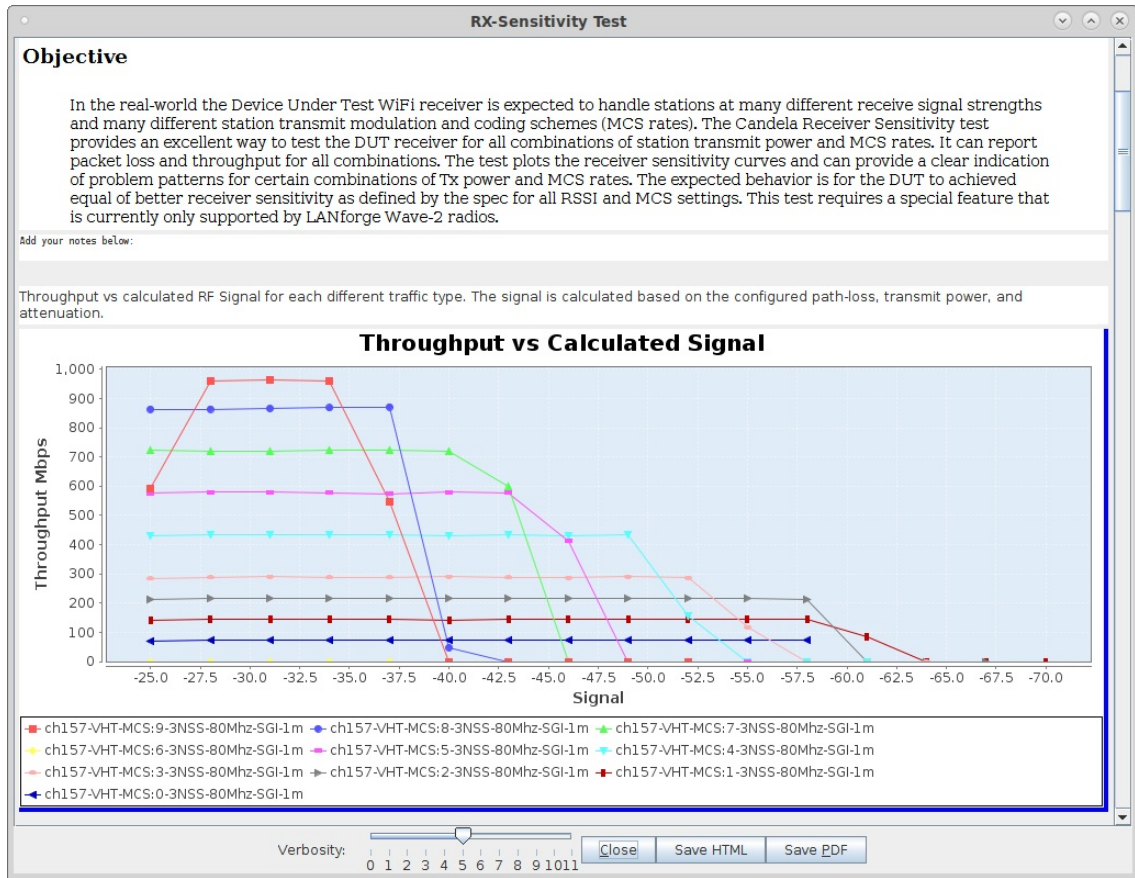

- D. When the test is complete, click the **Save HTML** button to save an HTML report and generate the PDF. The PDF file will be linked from the HTML page. You can also click 'Save PDF' and the browser will be directed to open the pdf file directly. Please see this [example RX Sensitivity Report](#)